

THIS DRAWING IS UNPUBLISHED. RELEASED FOR PUBLICATION  
 © COPYRIGHT BY TYCO ELECTRONICS CORPORATION. ALL RIGHTS RESERVED.

LOC	DIST	REVISIONS					
		P	LTR	DESCRIPTION	DATE	DWN	APVD
AF	50		D1	ECR-06-023927(REDRAWN IN AUTOCAD)	10NOV06	HMR	GP

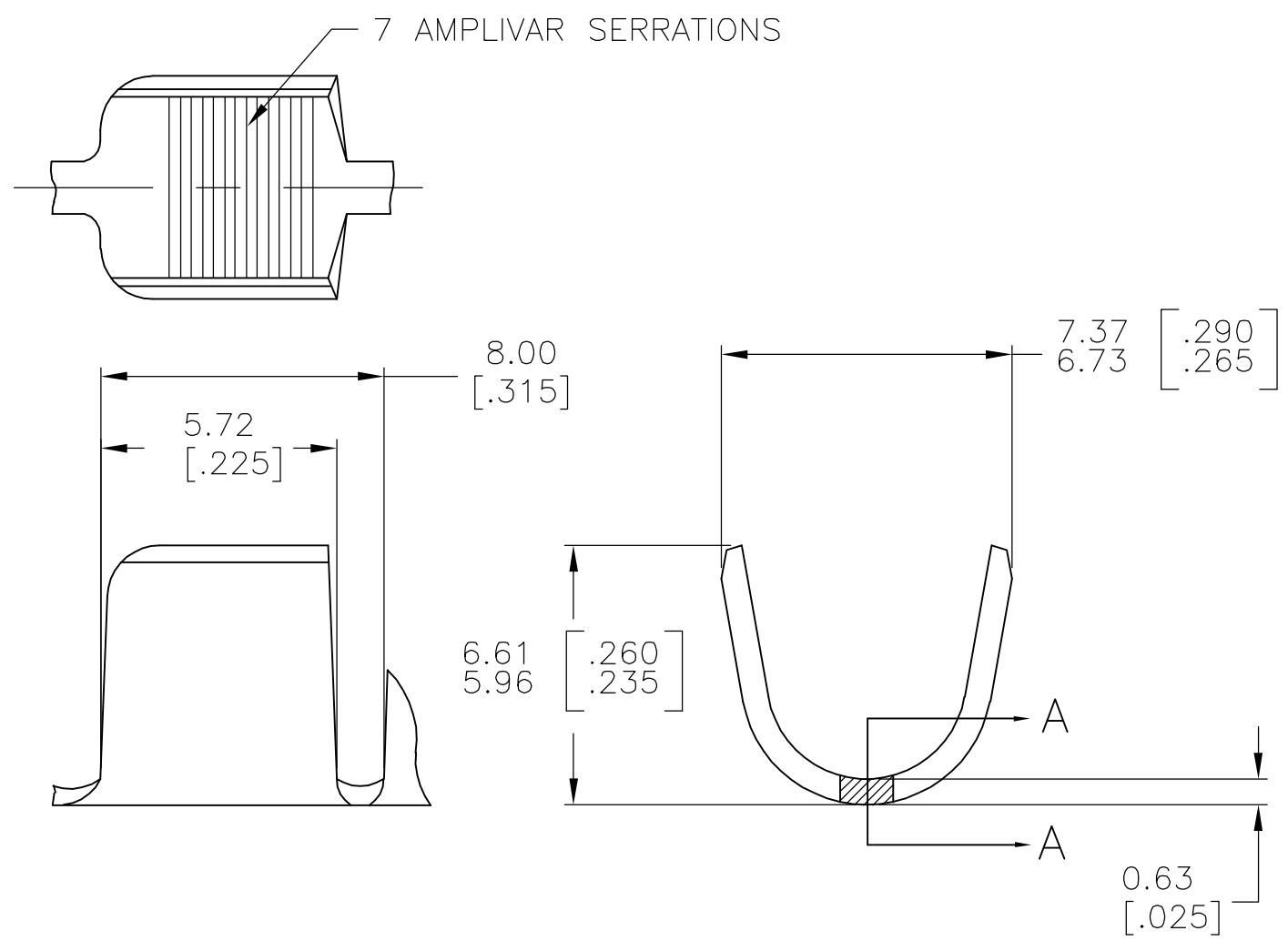

- CONTINUOUS STRIP ON REELS.
- DIMENSIONS IN BRACKETS ARE IN INCHES.
- FOR ADDITIONAL INFORMATION, SEE APPLICATION SPEC. 114-2002.
- WIRE RANGE: 7000-12000 CMA.
- CRIMP WIDTH: .250 F TYPE (AMPLIVAR PIGTAIL)  
 CRIMP HEIGHT (±.002)=(TOTAL CMA+27,100)/423,700  
 GENERAL APPLICATION GUIDELINES MUST BE FOLLOWED AS SPECIFIED IN CATALOG #82221  
 FOR APPLICATOR INFORMATION CALL:1-800-722-1111  
 FOR PRODUCT INFORMATION CALL:1-800-522-6752

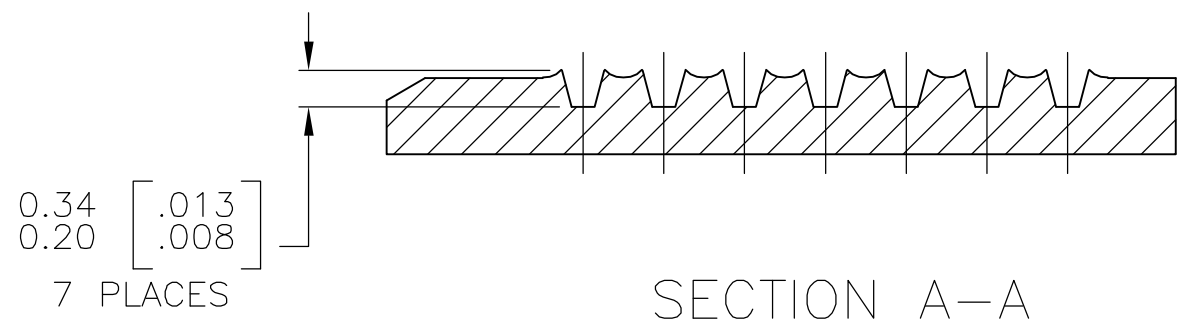

SECTION A-A  
SCALE 20:1

NONE	62295-2
TIN PLATE	62295-1
FINISH	PART NO

THIS DRAWING IS A CONTROLLED DOCUMENT.		DWN RAGHAVENDRA 10NOV06	Tyco Electronics Corporation Harrisburg, PA 17105-3608	
DIMENSIONS: mm [INCHES]		CHK G.D.PORTA		
TOLERANCES UNLESS OTHERWISE SPECIFIED:		APVD G.D.PORTA	NAME SPLICE, AMPLIVAR 7 SERRATIONS	
0 PLC ± - 1 PLC ± - 2 PLC ± - 3 PLC ± 0.38 [.015] 4 PLC ± - ANGLES ± 1' 0"		PRODUCT SPEC		
MATERIAL BRASS		FINISH SEE TABLE	APPLICATION SPEC	RESTRICTED TO
		WEIGHT -	SIZE A3	CAGE CODE 00779
		CUSTOMER DRAWING	DRAWING NO C-62295	RESTRICTED TO -
		SCALE 6:1	SHEET 1 OF 1	REV D1